

This information provided by:

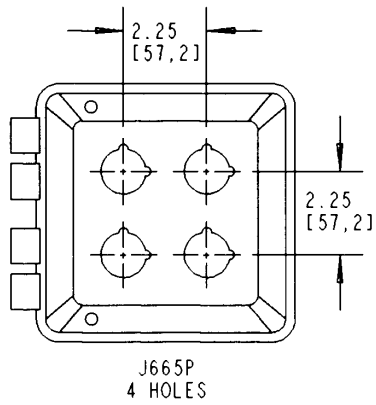

Gross Automation  
[www.grossautomation.com](http://www.grossautomation.com)

Call Toll Free:  
**800-349-5827**



J665P  
4 HOLES

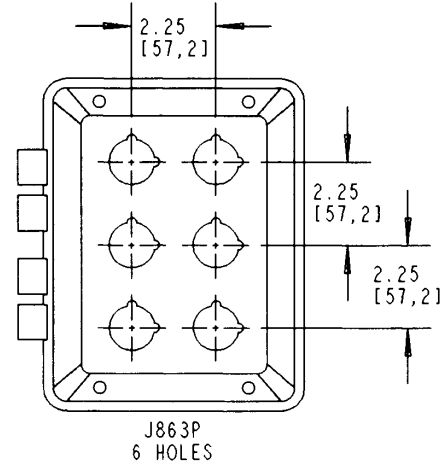

J863P  
6 HOLES

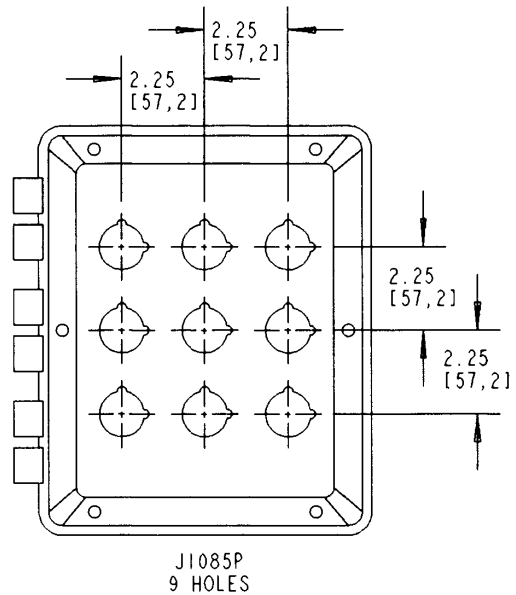

J1085P  
9 HOLES

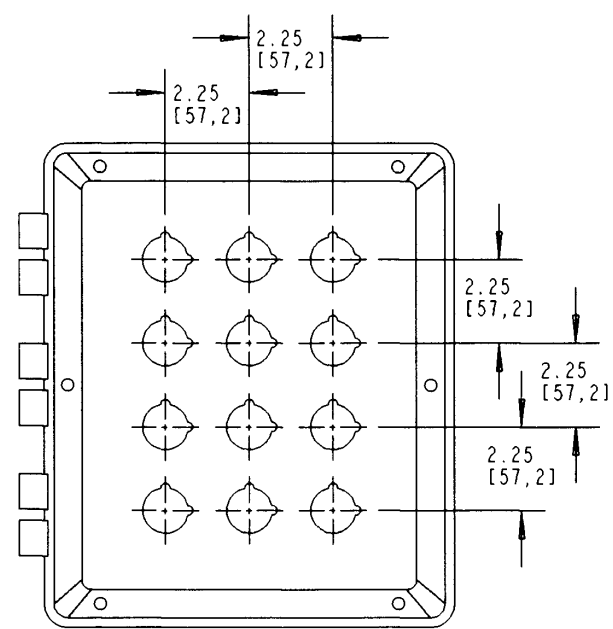

J12106P  
12 HOLES

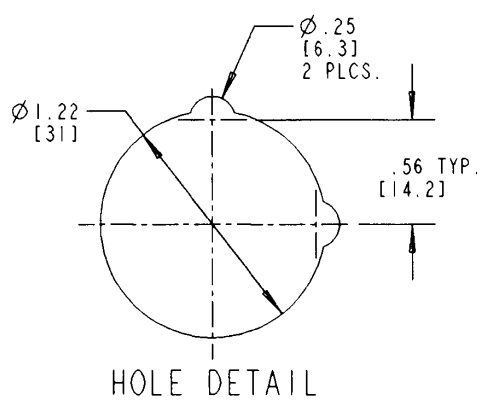

HOLE DETAIL

NOTES:  
 1. ALL DIMENSIONS ARE IN INCH/[MILLIMETERS].  
 2. SEE DRAWING AC01610 FOR ENCLOSURE DIMENSIONS.

|  |  |                            |                 |                               |
|--|--|----------------------------|-----------------|-------------------------------|
| TITLE<br><b>PUSH BUTTON ENCLOSURES</b> |  | DRN<br>DPR                 | DATE<br>1-14-04 | PART NO:<br><b>AS NOTED</b>   |
| LAMSON & SESSIONS                      | ALL DRAWINGS ARE THE PROPERTY OF LAMSON & SESSIONS AND SHALL NOT BE REPRODUCED IN ANY FORM WITHOUT LAMSON & SESSIONS' APPROVAL AND ARE TO BE PROMPTLY RETURNED UPON REQUEST. | APP.<br><i>[Signature]</i> | DATE<br>1/14/04 | DRAWING NO:<br><b>AC04490</b> |
|  |  |                            |                 | SHT. 1 OF 2                   |
|  |  |                            |                 | REV.                          |

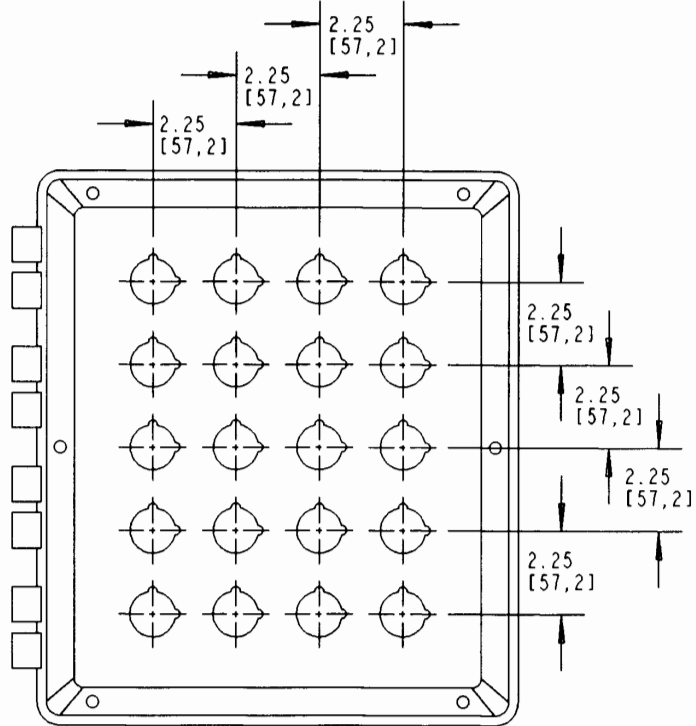

J14126P  
20 HOLES

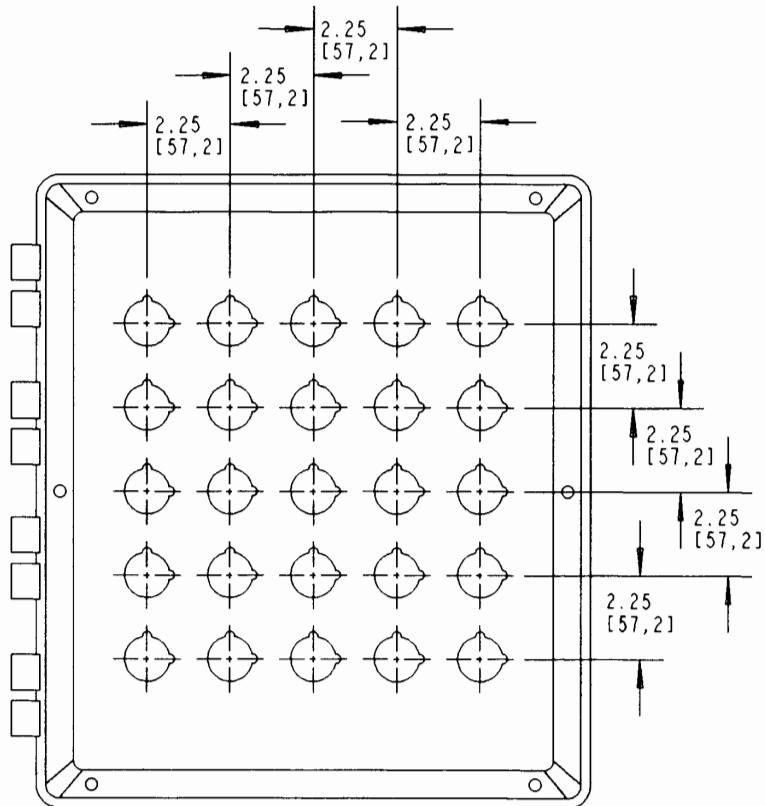

J16147P  
25 HOLES

- NOTES:  
 1. ALL DIMENSIONS ARE IN INCH/[MILLIMETERS].  
 2. SEE DRAWING AC01610 FOR ENCLOSURE DIMENSIONS.

|  |  |                    |                 |                             |      |
|--|--|--------------------|-----------------|-----------------------------|------|
| TITLE<br><b>PUSH BUTTON ENCLOSURES</b> |  | DRN<br>DPR         | DATE<br>1-14-04 | PART NO:<br><b>AS NOTED</b> |      |
| LAMSON & SESSIONS                      | ALL DRAWINGS ARE THE PROPERTY OF LAMSON & SESSIONS AND SHALL NOT BE REPRODUCED IN ANY FORM WITHOUT LAMSON & SESSIONS' APPROVAL AND ARE TO BE PROMPTLY RETURNED UPON REQUEST. | APP.               | DATE            | DRAWING NO:                 | REV. |
|  |  | <i>[Signature]</i> | 1/14/04         | <b>AC04490</b>              |      |
|  |  |                    |                 | SHT. 2 OF 2                 |      |