

This information provided by:

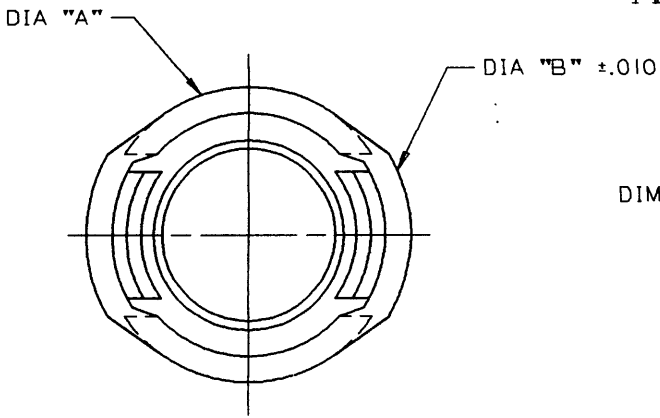

Gross Automation
www.grossautomation.com

Call Toll Free:
800-349-5827

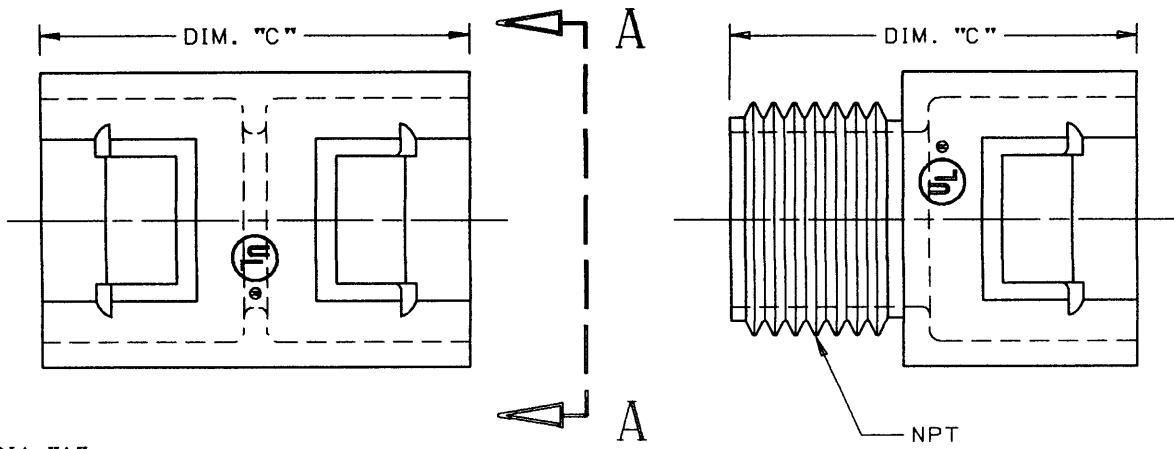

VIEW A-A

(TYP. FOR ALL (3) FITTINGS AS SHOWN)

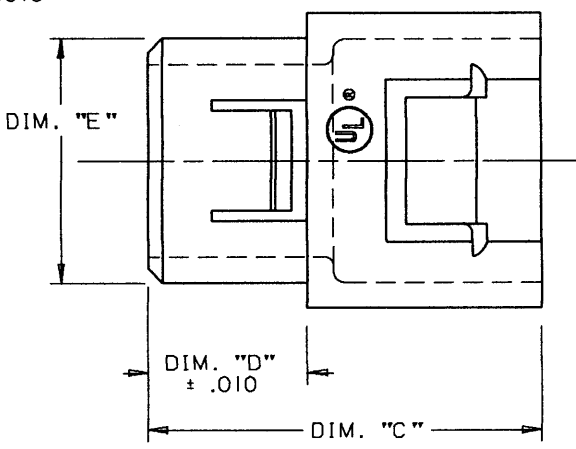

- NOTES:
1. MAT'L: KYNAR 710
 2. CHART DIMENSIONS ARE IN INCHES/MILLIMETERS.
 3. ONE PIECE QUICK CONNECT COUPLINGS, THREADED ADAPTERS AND SNAP-IN TERMINATOR ADAPTERS ARE SUITABLE FOR PLENUM LOCATIONS.

"PLENUM GARD COUPLINGS/ADAPTERS"						
PART NO.	SIZE	A	B	C	D	E
	IN MM	IN MM	IN MM	IN MM	IN MM	IN MM
A340F	1" 25.4	1.521 39	1.621 41	1.856 47	—	—
A343F	1" 25.4	1.521 39	1.621 41	1.856 47	.688 17	—
A353F	1" 25.4	1.521 39	1.621 41	1.666 42	.688 17	1.354 34

TITLE: PLENUM GARD COUPLINGS/ADAPTERS - 1"		DRN. RG	DATE 4/23/98	PART NO: SEE CHART
LAMSON & SESSIONS	ALL DRAWINGS ARE THE PROPERTY OF LAMSON & SESSIONS AND SHALL NOT BE REPRODUCED IN ANY FORM WITHOUT LAMSON & SESSIONS' APPROVAL AND ARE TO BE PROMPTLY RETURNED UPON REQUEST.	APP. CAH	DATE 5-5-98	DRAWING NO: AC03394
		REV.		