

This information provided by:

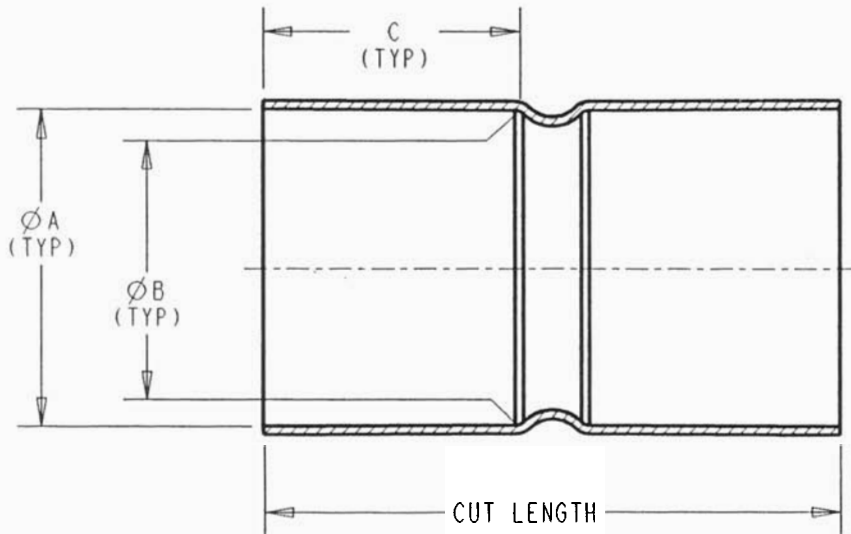

Gross Automation
www.grossautomation.com

Call Toll Free:
800-349-5827



PART NUMBER	NOMINAL SIZE	RAW MATERIAL CUT LENGTH PRIOR TO SWEDGING	BELL DIMENSIONS		
			DIA 'A'	DIA 'B'	DIM 'C'
E240RF	6"	11	6.69 [170]	6.64 [169]	5.4 [137]
E242J	2"	5	2.40 [61]	2.38 [60]	2.1 [54]
E242JGT	2"	6	2.39 [61]	2.37 [60]	2.3 [57]
E242L	3"	6	3.54 [90]	3.51 [89]	3.1 [79]
E242N	4"	8	4.54 [115]	4.51 [114]	3.6 [92]
E242NGT	4"	9-1/4	4.52 [115]	4.49 [114]	4.0 [102]
E242NT	4"	8	4.38 [111]	4.36 [110]	3.0 [76]
E242NTW	4"	7-1/2	4.38 [111]	4.36 [110]	3.0 [76]
E242P	5"	9	5.61 [143]	5.57 [142]	4.0 [102]
E242R	6"	10	6.69 [170]	6.64 [169]	4.5 [114]

NOTE: DIMENSIONS ARE IN INCHES/MILLIMETERS

TITLE: COUPLING - FABRICATED		DRN: RG	DATE: 10/19/05	PART NO: SEE CHART
LAMSON & SESSIONS	ALL DRAWINGS ARE THE PROPERTY OF LAMSON & SESSIONS AND SHALL NOT BE REPRODUCED IN ANY FORM WITHOUT LAMSON & SESSIONS' APPROVAL AND ARE TO BE PROMPTLY RETURNED UPON REQUEST.	APP: <i>[Signature]</i>	DATE: 10/19/05	DRAWING NO: AC04798
				REV.