

This information provided by:



Gross Automation
www.grossautomation.com

Call Toll Free:
800-349-5827

SIZE	PART NUMBER	THREAD SIZE	A	B	C	D	E
1/2"	LN20D LN20DA	1/2-14NPT	0.56 (14.2)	1.50 (38.1)	1.99 (50.5)	1.34 (34.0)	1.19 (30.2)
3/4"	LN20E LN20EA	3/4-14NPT	0.56 (14.2)	1.73 (43.9)	2.25 (57.2)	1.63 (41.4)	1.44 (36.6)
1"	LN20F LN20FA	1-11-1/2NPT	0.69 (17.5)	1.86 (47.2)	2.58 (57.9)	1.99 (50.5)	1.75 (44.5)

ASSEMBLY NOTES

- CUT CONDUIT SQUARE AND CLEAN.
- PUSH WASHER UP AGAINST STOP ON CONDUIT SIDE OF FITTING.
- PULL O-RING OVER O-RING GROOVE ON NPT SIDE OF FITTING.
- SCREW CONDUIT ONTO FITTING UNTIL IT CONTACTS WASHER OVER ENTIRE CIRCUMFERENCE.
- PLACE FITTING INTO KNOCKOUT AND TIGHTEN LOCKNUT (NOT FITTING).

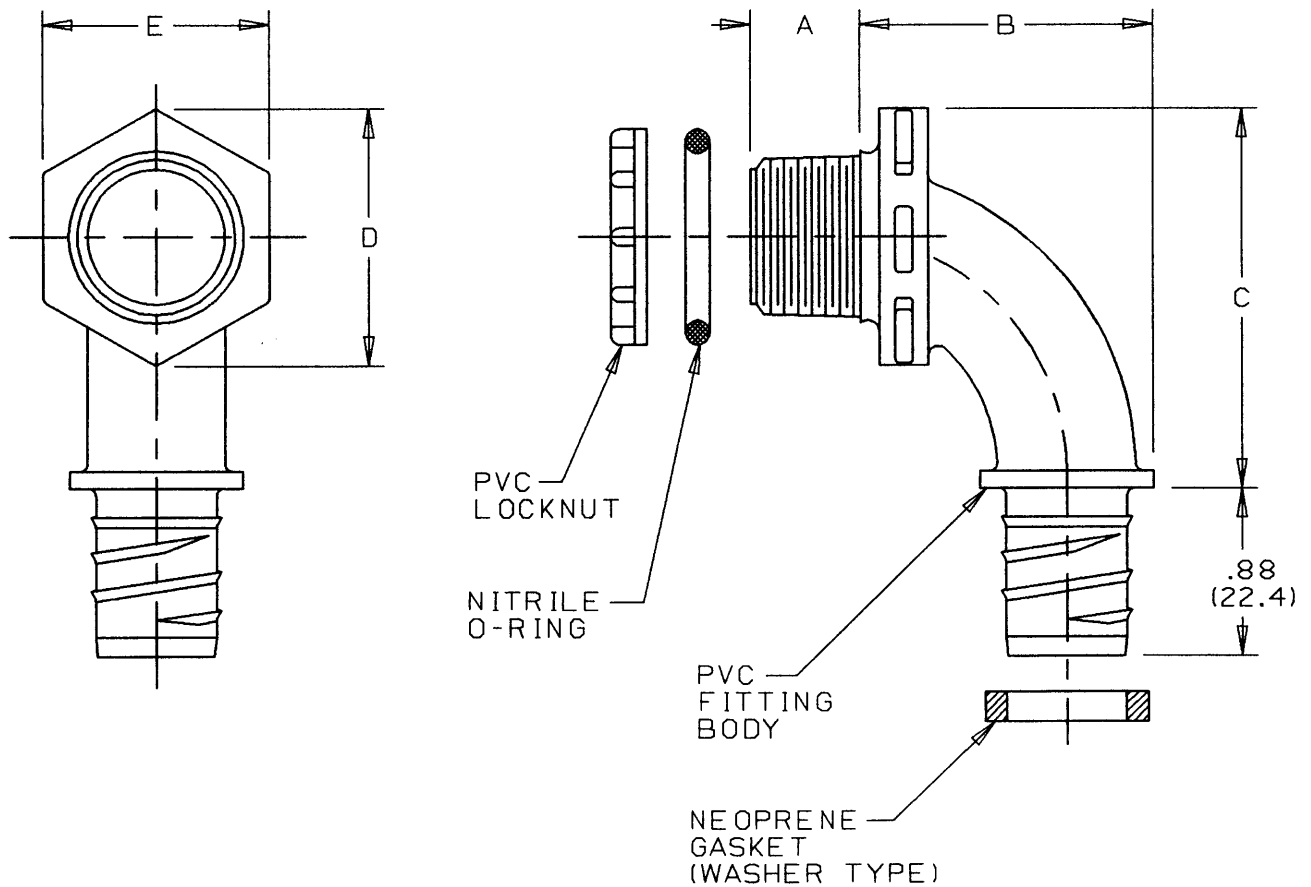

TITLE: 90° CARFLEX SPIRAL FITTING

DRN. SLK
DATE 6-92

PART NO: SEE TABLE

LAMSON & SESSIONS

ALL DRAWINGS ARE THE PROPERTY OF LAMSON & SESSIONS AND SHALL NOT BE REPRODUCED IN ANY FORM WITHOUT LAMSON & SESSIONS' APPROVAL AND ARE TO BE PROMPTLY RETURNED UPON REQUEST.

APP. DM
DATE 6-92

DRAWING NO: AC00828

REV. A