

This information provided by:



Gross Automation
www.grossautomation.com

Call Toll Free:
800-349-5827

SIZE	PART NUMBER	THREAD SIZE	A	B	C
1/2"	LN43D LN43DA	1/2-14NPT	0.56 (14.2)	1.34 (34.0)	1.19 (30.2)
3/4"	LN43E LN43EA	3/4-14NPT	0.56 (14.2)	1.63 (41.4)	1.44 (36.6)
1"	LN43F LN43FA	1-11-1/2NPT	0.69 (17.5)	1.99 (50.5)	1.75 (44.5)

ASSEMBLY NOTES

1. CUT CONDUIT SQUARE AND CLEAN.
2. PUSH WASHER UP AGAINST STOP ON CONDUIT SIDE OF FITTING.
3. PULL O-RING OVER O-RING GROOVE ON NPT SIDE OF FITTING.
4. SCREW CONDUIT ONTO FITTING UNTIL IT CONTACTS WASHER OVER ENTIRE CIRCUMFERENCE.
5. PLACE FITTING INTO KNOCKOUT AND TIGHTEN LOCKNUT (NOT FITTING).

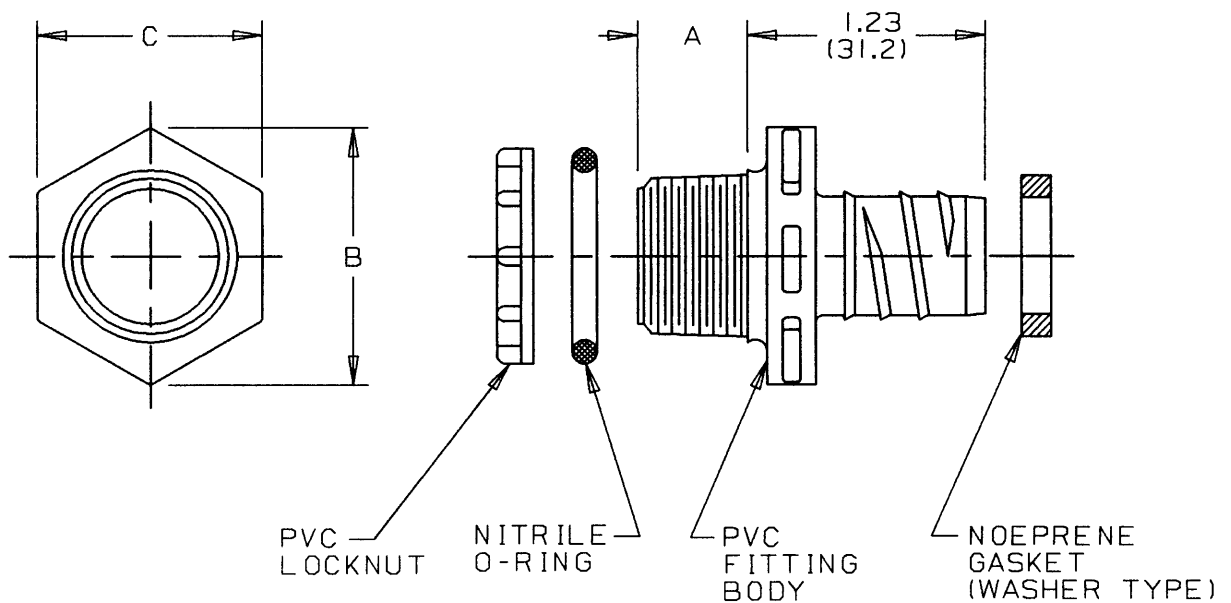

TITLE: STRAIGHT CARFLEX SPIRAL FITTING

DRN. DATE
SLK 6-92

PART NO:

SEE TABLE

LAMSON & SESSIONS

ALL DRAWINGS ARE THE PROPERTY OF LAMSON & SESSIONS AND SHALL NOT BE REPRODUCED IN ANY FORM WITHOUT LAMSON & SESSIONS' APPROVAL AND ARE TO BE PROMPTLY RETURNED UPON REQUEST.

APP. DATE
DM 6-92

DRAWING NO:

AC00827

REV.
A